

# Kinetico 2040s OD

**OVERDRIVE**<sup>®</sup>  
ENHANCED

Non-Electric,  
High Performance  
Water Conditioning System



 **Kinetico**<sup>®</sup>  
home water systems

Conditioned Water 24 Hours a Day, Every Day

Simple, Reliable and Economical Operation

Twin Tank Design

Certified Performance

Installation and Service by Trained Water Treatment Professionals

Regeneration requires only:

- 7 gallons of water
- 11 minutes
- 1 lb. of regenerant

## What Makes The Kinetico Overdrive<sup>®</sup> Enhanced 2040s OD Different?

- 1. Non-Electric Operation.** Reliable. No timers or computers to set, adjust, repair or replace.
- 2. Metered, Demand Service.** Unlimited supply of clean, soft water. Eliminates guesswork, water and regenerant waste, and hard water breakthrough.
- 3. Twin Tank System.** Unlimited supply of clean, conditioned water. Enables system to regenerate with clean, conditioned water.
- 4. Overdrive Enhanced.** All tanks are in service simultaneously. Increases performance, efficiency, flow rate and media life.
- 5. High Flow Rate.** System keeps up with the conditioned water needs of today's demanding households.
- 6. Large Porting Size.** Perfectly suited for larger plumbing found in many homes. Up to 1 1/2 inch.
- 7. Efficient Hardness Removal.** Assures consistent and continuous clean, soft water. Saves money on soaps and cleaners. Protects plumbing and appliances.
- 8. High Efficiency, Packed Resin Bed.** More efficient hardness removal. Conserves regenerant and water. Increases performance.
- 9. Efficient Use of Water and Regenerant.** Low water consumption. Less money spent on regenerant.
- 10. Corrosion-Resistant Valve and Tanks.** Long lasting. Can endure harsh environments.
- 11. Soft Water, Countercurrent Regeneration.** Increases product efficiency and water quality.
- 12. Automatic Operation.** Just add regenerant.
- 13. Outstanding Warranty.** Dependability, peace of mind.

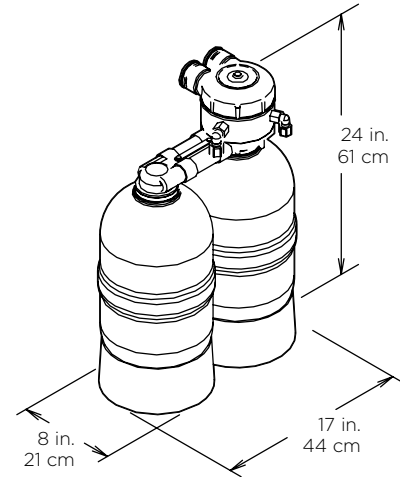

### Brine Tank Options:

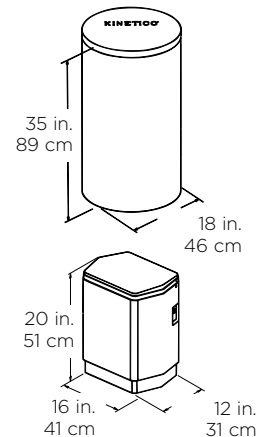

### Independent Laboratory Certification

Select Kinetico products are tested and certified by Independent Laboratories such as NSF. For specific claims and certifying laboratories, refer to performance data sheets or consult your local Kinetico Dealer.



## Kinetico Super Hi-Efficiency Softener

The Kinetico Model S650 combines non-electric, twin softener tank technology with special resin beads that allows it to consistently be the most efficient softener Kinetico offers.

With only 7 gallons of waste water and one pound of salt usage per cleaning cycle, the Model S-650 is not only environmentally friendly, but also saves thousands of gallons a year in waste water compared to an electric softener.

With just an 11 minute cleaning cycle, you won't have hours of noisy cleaning cycles at 2 am as with an electric softener. And since the Model S-650 is totally water powered, you'll never have to reset timers after a power outage.

Choose our small 16" x 12" x 20" salt tank if space is tight. We can actually stack the softener on a shelf above the salt tank to conserve even more space.

Choose the 18" x 35" salt tank if you want more storage capacity. A four person family using 300 gallons of water a day in 20 grains of hard water would only need to fill this tank about every 7 ½ months.

Simple, easy, one step maintenance. That's Kinetico!